



HAWKER LEVEL CONTROL SYSTEMS

Type E13A Multi-Electrode Holder

For use with all level controllers and alarms operating in aqueous (conducting) liquids i.e. water, acids, chemical effluent, beverages etc.

- Spacer saver.
- Accommodates up to 5 electrodes.
- Universal flange fitting.
- Corrosion resistant.
- Intrinsically safe and pressure tight version available.
- Electrodes available for most aggressive liquids, (i.e. PPA* coated Stainless Steel, Titanium, Monel, Hastelloy C)

PPA* plastic coating WRAS No 1610508

The Hawker multi electrode holder is moulded in tough glass filled polypropylene and accommodates up to 5 plastic coated 8mm electrodes up to 3m long (longer lengths are available via threaded couplers), it is ideal for water tanks, chemical storage tanks and bunds. 5 electrodes enable the E13A to be used for pump control with high and low alarms. Use centre hole for earth electrodes. Mounting (Type 81/MS or 81/SS) and steady (Type 218/SS) brackets and separators (Type 214) etc are available. Always use the well proven, AC or P3/P4 or DC1/P series controllers incorporating CSD circuitry.

The Universal Flange is suitable for:-

- ANSI 3" 150lb
- DN 80 PN16 flush fitting or 4 hole only.
- BS10 table D 3"
- Hawker type 81 or 81/SS bracket
- Fixing kits available (ref 215) to mount E13 to bracket

Temp Range:- -20°C to + 85°C

Weight:- 0.55 Kg

Intrinsically safe application model E13A/IS to Ex ia ii C T4 is available. Both the standard and intrinsically safe versions are available to IP67 if required
Note IP67 Versions require the electrodes to be threaded to allow fitting into holder

Electrodes are ordered separately to the E13A. When ordering electrodes please specify-

- 'L' +70mm = electrode lengths for E13A
- 'L' +12mm = electrode lengths for E13A/IP67

Electrode Material	Order Ref	Size	Maximum Available Length
Uncoated 316L Grade Stainless Steel	187	8mm	3m
PPA Coated 316L Grade Stainless Steel	188	8mm	3m
Uncoated Titanium	193	8mm	3m
Uncoated Monel	194	8mm	3m
Uncoated Hastelloy	196	8mm	3m

Note 2 If longer electrode lengths are required this can be achieved by threading and coupling the rod (additional cost).

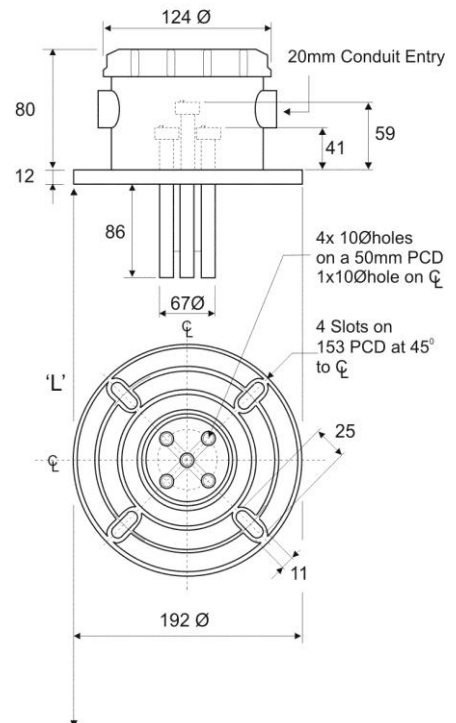
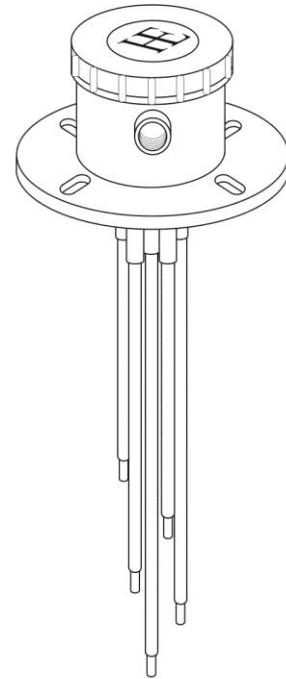

This product has been designed and complies to the relevant standards as listed in its certificate of conformity. The installer/user must ensure compliance. Because of continuing development we reserve the right to change the specifications without notice

HAWKER ELECTRONICS LTD.

57 The Avenue,
 Rubery Industrial Estate,
 Birmingham B45 9AL, ENGLAND
 Telephone: +44 (0)121-453-8911 Fax: +44(0)121-453-3777
 email: info@hawker-electronics.co.uk www.hawker-electronics.co.uk



FM 10000



BRITISH MADE