



PMA 10

## Oxygen Analyser Series PMA®

Portable version PMA 10  
for mobile oxygen measurement

### Special Features

- Portable and rugged instrument, light-weight
- Analogue and digital linear indication
- Physical measuring principle
- Small stagnant volume, fast response time
- High accuracy and reliability
- Approved according to DIN EN 14181 resp. to 13th and 17th BImSchV and TÜV certificate TA-Luft as option

### Application

Due to the extremely fast response time of the M&C magneto-dynamic measuring cell with no stagnant volume as well as the negligible cross sensitivity from other sample gas components, the portable M&C oxygen analyser PMA 10 has a wide variety of applications. The analyser is a suitable and reliable instrument for monitoring oxygen concentrations in various gas analytical control applications including flue gas-, inert gas-, fermentation processes-, food packing machines-, ambient air- and laboratory process control measurements.

### Description

The portable M&C oxygen analyser PMA 10 is a non-thermostated instrument which has been designed for continuous and discontinuous measurement of oxygen concentrations in dry and particle-free sample gases.

The PMA 10 is a reliable and easy-to-operate instrument and immediately operable. The light-weight instrument is built into a portable housing. The four measuring ranges are displayed on the analogue meter with 30%/100% scale and the 100 vol% O<sub>2</sub> range also on the digital meter. One output signal 0-1 V is available as standard. Sample gas connections as well as a connector for the output signal are located on the front panel of the analyser. The connectors for incoming power supply and optional O<sub>2</sub> alarm contact are located at the rear panel. The sample gas enters the analyser via an internal protective fine-filter. The required flow rate can be adjusted at the flowmeter with needle valve, mounted on the front panel upstream the M&C measuring cell.

Options: mA-output signal, O<sub>2</sub> alarm, rechargeable battery, internal pump and TÜV certificate.

### Measuring principle of M&C oxygen analyser

The PMA 10 utilises the paramagnetic principle of operation to measure oxygen concentrations. The analyser measures the paramagnetic susceptibility of the oxygen in the sample gas by means of the M&C magneto-dynamic measuring cell. The physical property which distinguishes oxygen from other gases is its paramagnetism. It is significantly higher comparing to other common gases. This operation principle is one of the most accurate and reliable procedures to determine the oxygen concentration in a gas mixture from 0 to 100 vol%. The robust M&C cross-flow cell has no stagnant volume. Advantages are the fast response time, the flow rate up to 60 l/hr, the small volume of 2 ml, the extremely low drift, the absolute linearity and the negligible cross sensitivity against other sample gas components. With a proper sample conditioning and pressure, the M&C cell will never need replacing. The dumbbell with a small mirror at its centre is mounted in a strong inhomogeneous magnetic field. The paramagnetic oxygen strengthens the forces on the diamagnetic dumbbell and causes a shifting which is detected by a system consisting of light beam, mirror and a photo cell. A compensation current is induced via the feedback coil on the dumbbell and leads to a reset of the dumbbell into its zero-position. The required current is linearly proportional to the oxygen concentration.

## Gas flow diagram PMA10

1. Fine filter
2. Flowmeter with needle valve
3. Oxygen measuring cell PMA
4. Option internal pump

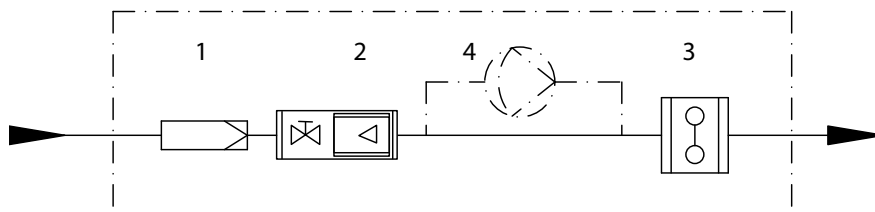

## Dimensions

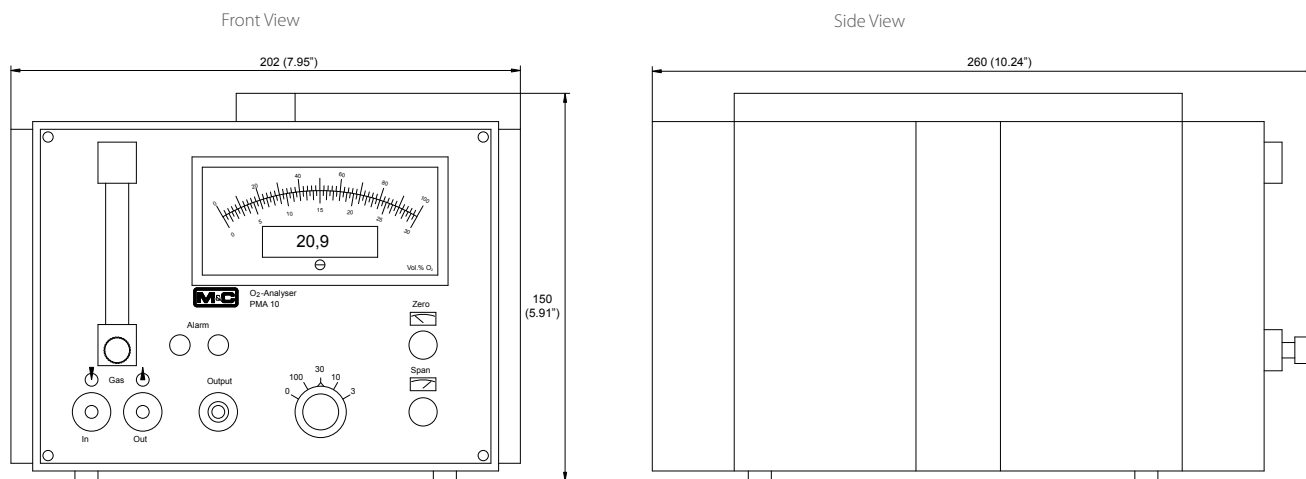

Dimensions in mm (Inch)

## Technical Data

Version PMA 10 portable oxygen analyser	
Part No.	01 A 1000 : PMA 10, power supply 230 V 50 Hz, output signal 0-1 V; 01 A 1000a = 115 V 60 Hz
Measuring ranges	selectable for 0-3, 0-10, 0-30 and 0-100 vol% O <sub>2</sub> , linear
Indication	analogue / digital meter: analogue meter selectable for each range with a scale of 0-30 and 0-100 % digital meter, 3 1/2 digit 9 mm (0.35") high LCD for 0-100 % O <sub>2</sub> reading, selectivity 0.1 vol% O <sub>2</sub>
Output signal	0-1 V DC, non-isolated, load > 100 kΩ, for each selected range; option: 0-20 mA* or 4-20 mA* for each selected range, non-isolated, max. load 300 Ω Part no. 01 A 9000
Response time for 90 % FSD	< 3 seconds at 60 NI/h air
Accuracy after calibration	analogue = ±1 % of span / digital = ±0.1 vol% O <sub>2</sub> error of precision
Reproducibility	analogue = < 1 % of span / digital = ± 0.1 vol% O <sub>2</sub> error
Influence of ambient temperature	zero point ±0.02 vol% O <sub>2</sub> / °C; sensitivity ±0.1 vol% O <sub>2</sub> / °C
Influence of barometric pressure	The oxygen reading varies in direct proportion to changes of the barometric pressure.
Influence of sample gas flow	variation in gas flow between 0-60 NI/h air will cause a difference of < 0.1 vol% O <sub>2</sub> .
Sample gas inlet pressure	0.01 up to 1 bar g, (PMA 10 required admission pressure for competent flow rate, no pump inside) option: PMA 10 with internal pump, capacity 0.9 NI/min. without pressure, Part-No.: 01 A 9102
Sample gas outlet pressure	Outlet of analyser must discharge freely into atmosphere.
Flow rate of sample gas	max. 60 NI/h air, adjustable with needle valve on the flowmeter 7-70 NI/h
Temperature of sample gas	-10 °C up to +40 °C (14 °F to 104 °F), dry gas
Analyser temperature	according to ambient temperature, non heated version
Ambient temperature	-10 °C up to +55 °C (14 °F up to 131 °F)
Storage temperature	-20 °C up to +60 °C (~-4 °F up to 140 °F), relative humidity 0-90 % RH
Power supply	internal power unit for 230 V AC standard or 115 V AC available (a)* +/-10 %, 40-60 Hz, 8 VA option: rechargeable battery, recharged by the internal power unit, Part no. 01 A 9050 battery capacity 10 h, recharge time of battery 14 h with instrument off
Electrical connections	mains supply: 3-pole chassis plug with 2m of cable; signal: 3-pole plug
Materials in contact with sample gas	Platinum, Glass, Polypropylene, Stainless Steel 316, FPM, Epoxy resin
Sample gas connection	PP-hose nipple for DN 11-4 mm tube
Protection / electrical standard	IP 41 EN 60529 / EN 61010
Housing / colour	portable plastic housing / gray
Dimension / weight	height 150 mm (5.91"), width 202 mm (7.95"), depth 260 mm (10.24") / approx. 3 kg (6.61 lbs)
Alarms	option: O <sub>2</sub> alarm low* or high* adjustable 0-100 % O <sub>2</sub> , relays contact NC/NO Part no. 01 A 9150 additional with acoustic signal and auto reset after 30 sec. Part-No.: 01 A 9155 additional with acoustic signal and manual reset, Part-No.: 01 A 9156
Certificate	option: approved according to DIN EN 14181 resp. to 13th and 17th BImSchV and TA-Luft, Part-No.: <b>01 A 9160</b>

\* Please specify with order.

In case the options alarm and pump are both required, a rechargeable battery is automatically obliged.

In case the option "acoustic alarm" required, the option "O<sub>2</sub> alarm" is obliged.

Option "TUV approved" includes 0\*/4\*-20 mA signal output, as further options only rechargeable battery and internal pump available.

## WARNING!

## IMPORTANT!

An external fine filter must always be used at the gas inlet of the analyser. Depending on the composition of the sample gas, it may be necessary to use a sample conditioning system. Without precautions, the analyser is only suitable for measuring of non-hazardous gases or gas mixtures in non-hazardous areas.